

SDR-4000 WML

Wireless Modem *Lite* for Software Defined Radio Applications



Preliminary



Benefits

- Commercial-off-the-shelf (COTS) and ready to support complex waveforms requiring high-speed, low-latency deterministic operation
- Substantially reduce costs and schedules associated with waveform development and porting by using Spectrum's data flow examples that include source code
- Increase communications range and improve payload data throughput with ultra low additive jitter clock circuitry design, essential to maximize energy-per-bit/noise spectral density
- Reduce your time-to-deployment by up to two years using Spectrum's Modified COTS process for rapid optimization of size, weight, power and cost
- Accelerate application development, simplify the programming model, and ensure code portability with *quicComm*™ API, common across all *flexComm*™ products

Applications

The SDR-4000 Wireless Modem *Lite* (SDR-4000 WML) can be used for waveform development or for fielded radio applications. Typical applications include:

- Tactical Military Communications (MILCOM)
- Multiple-input Multiple-output (MIMO) and Smart Antenna applications supporting multi-channel coherent operation
- Military Satellite Communications (MILSATCOM) gateways, terminals and hubs
- Electronic Warfare (EW) including Electronic Attack – jamming
- Tactical data link for mobile and base station sites

Features

- Small size 3U CompactPCI, form factor
- Board set consisting of XMC-3321 dual transceiver module mounted on PRO-4600 *Lite* carrier card
- Conduction-cooled or air-cooled versions
- Intermediate Frequency (IF) to Ethernet processing for industry standard IF frequencies including 10.7, 21.4, and 70 MHz
- XMC interface (ANSI VITA 42.0) supporting one Solano® high-speed, low latency deterministic data link between mezzanine and carrier card
- PCI 32-bit / 33 MHz bus for control
- IF to digital conversion via two 14-bit A/D converters sampling at 96.0 MSPS
- Digital to IF conversion via two 14-bit D/A converters sampling at 192.0 MSPS
- Internal or external 10 MHz reference oscillator drives on-board sample clock. Alternately, use an external sample clock for sampling rates up to 105 MSPS for the ADC and up to 300 MSPS for the DAC.
- Two 12-bit D/A converters up to 100 KSPS suitable for driving AGC input of an RF front-end
- Four 12-bit A/D converters up to 100 KSPS suitable for reading Receiver Signal Strength Indication (RSSI) output of an RF front-end
- User-programmable Xilinx® Virtex-4™ SX55 FPGA on XMC-3321 for wideband processing and low-power consumption
- TMS320C6416T digital signal processor (DSP) on PRO-4600 for baseband processing and compatibility with legacy waveforms
- Freescale™ MPC8541E on PRO-4600 general purpose processor (GPP) for baseband processing and control
- Real-time operating system using Wind River® VxWorks® with Tornado® or Green Hills® INTEGRITY® with MULTI®

Description

The SDR-4000 WML provides black-side (IF-to-Ethernet) digitization and processing of complex waveforms. It consists of an XMC-3321 dual transceiver module mounted onto a 3U cPCI PRO-4600 *Lite* carrier card. Each SDR-4000 WML provides modem, link and network layer processing of a software defined radio. "*Lite*" refers to the version of PRO-4600 that supports a digital signal processor (DSP) and a general purpose processor operating at a reduced speed of 400 MHz. Operating the GPP at a reduced speed results in a lower power requirement per slot compared to the standard PRO-4600. For applications requiring a user FPGA, the SDR-4000 WML supports a Virtex-4 SX55 user FPGA on the XMC-3321 I/O module, which mounts onto the PRO-4600 *Lite* carrier card.

The PRO-4600 and XMC-3321 have been architected to support waveforms requiring low latency deterministic operation to maintain synchronization of the frequency-hopped Tactical MILCOM network. This is accomplished by placing control on a PCI bus that is separate from the data path. High-speed data is transferred from the XMC-3321 to the PRO-4600 *Lite* using Spectrum's Solano® communications technology over an ANSI VITA 42.0 XMC interface.

The SDR-4000 WML is available in either an air-cooled or conduction-cooled configuration and supports two IF input channels, two IF output channels, an internal or external 10 MHz reference and high speed sample clock, Gigabit Ethernet, RS232 and JTAG connectivity. The SDR-4000 WML employs a combination of a Xilinx Virtex-4 FPGA, a TI TMS320C6416T DSP and an MPC8541E General Purpose Processor.



SDR-4000 Wireless Modem *Lite*

Block Diagram

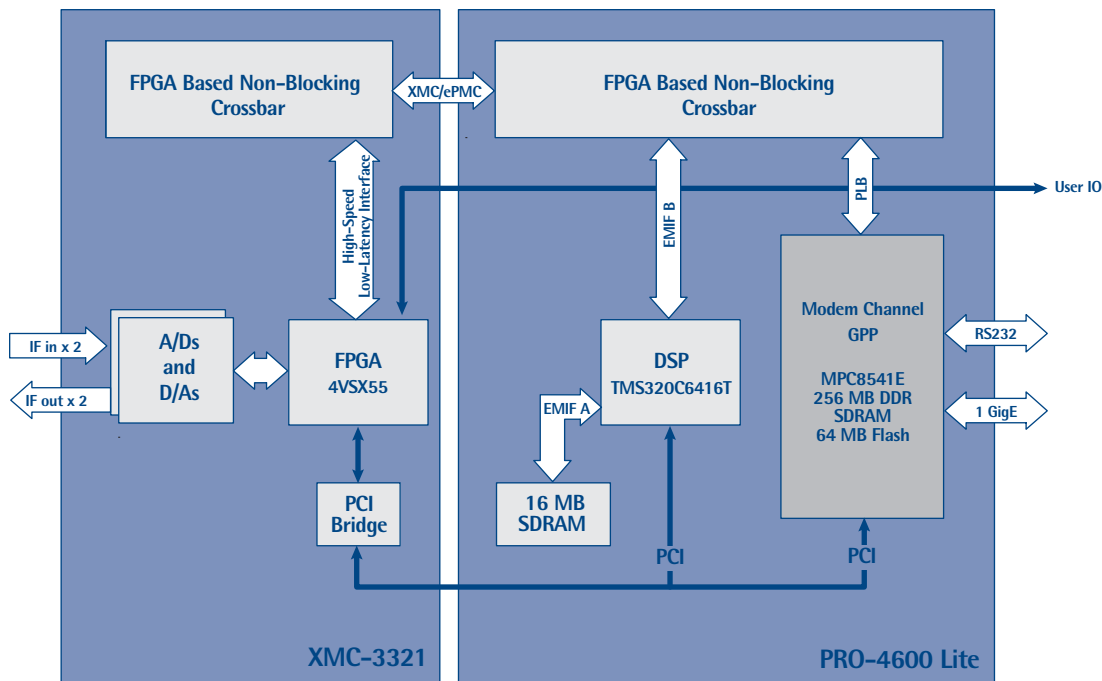

Figure 1. Block Diagram

Architecture

[PRO-4600 *Lite* SDR Processing Engine]

The PRO-4600 *Lite* is a 3U CompactPCI heterogeneous processing engine that employs a combination of a TMS320C6416T DSP and a 400 MHz MPC8541E general purpose processor to support the processing requirements of size, weight and power-limited SDR applications. The PRO-4600 *Lite* is equipped with a single-width XMC site, capable of hosting Spectrum's ePMC (Solano) modules and industry-standard PMC and XMC modules. For more information on the PRO-4600 see the PRO-4600 (no User FPGA option) datasheet on at www.spectrumsignal.com.

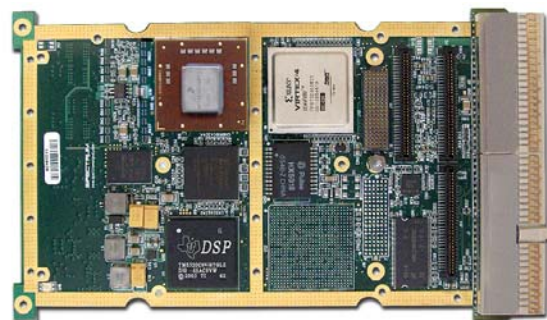

Figure 2. PRO-4600 *Lite* 3U SDR Processing Engine

[XMC-3321 Dual Transceiver XMC Module]

The XMC-3321 supports industry standard IF frequencies including 10.7, 21.4 and 70 MHz through the use of dual 14-bit A/D converters sampling at up to 105 MSPS and dual 14-bit D/A converters sampling at up to 300 MSPS in a single-width XMC form factor. The XMC (ANSI VITA 42.0) standard is fully compatible with IEEE P1386.1 PMC standard but offers the additional benefit of dedicated high-speed links between an XMC-compliant carrier and its mezzanine modules. The XMC-3321 supports Spectrum's Solano Communication Technology via the XMC high-speed interface. The module also features a single user programmable Xilinx Virtex-4 FPGA device for wide bandwidth signal processing and filtering in the digital domain. For more information on the XMC-3321 see the XMC-3321 datasheet at www.spectrumsignal.com.



Figure 3. XMC-3321 Dual Transceiver XMC Module

Software

[[quicComm Software Development Kit \(SDK\)](#)]

The SDR-4000 WML software interface is via the *quicComm* SDK that is available on all supported platforms. *quicComm* software abstracts the underlying hardware providing users with basic transport level access and control of Spectrum's *flexComm* products. This significantly accelerates user application development. *quicComm* is standard across all *flexComm* products, allowing code portability. This software includes a board support package for control and data handling which allows configuration and control of the data links between processors and mezzanine cards, initiates and manages data transfers, manages interrupts, and is used to load applications onto the DSP and user-programmable FPGA.

[[Operating System](#)]

The PRO-4600 supports the Green Hills INTEGRITY real-time operating system (RTOS) with MULTI Integrated Development Environment (IDE) and the Wind River VxWorks RTOS with Tornado. Both of these operating systems are designed for use in embedded systems that require maximum reliability.

Services

[[Modified COTS Optimization](#)]

The SDR-4000 WML hardware and software architecture is based on Spectrum's Tactical MILCOM reference designs resulting in a quick turn-around to optimize the product to meet the size, weight, power, cost and/or ruggedization characteristics of fielded applications. The SDR-4000 WML's independent hard and soft real-time communications fabrics allow the use of custom data-routing techniques. Using the Modified COTS (MCOTS) process, Spectrum works with its customers to provide an MCOTS solution while substantially minimizing the time-to-deployment. For more information on the benefits of Spectrum's MCOTS process, please contact Spectrum Sales.

[[Customer Training](#)]

Spectrum's training workshops are designed to get your team up and running in the shortest time possible by using a combination of lectures and at least 60% hands-on experience with your system. This service is an invaluable tool that generates significant cost savings and reduces risk for Spectrum customers. The standard SDR-4000 training consists of two days instruction from a Spectrum Applications Engineer.

[[Custom Application Development](#)]

Spectrum's Application Engineering Services (AES) can assist development of your custom application software, including U.S. Department of Defense and ITAR-controlled projects. The scope of these services is tailored to customers' needs, ranging from complete subsystem development to support for SCA operating environment and waveforms. Spectrum's AES team partners with customers' internal application development engineers to augment their development resources. For more information, please see the Application Engineering Services datasheet at www.spectrumsignal.com.

Specifications

[general]	IF Conversion and baseband processing FPGA User Device DSP Processor General Purpose Processor External Reference Oscillator Internal Reference Oscillator External Sampling Clock User Interface	XMC-3321 dual transceiver module mounted on PRO-4600 <i>Lite</i> SDR processing engine Xilinx Virtex-4 SX55 on XMC-3321 Texas Instruments 600 MHz TMS320C6416T processor with 16 MB SDRAM on PRO-4600 400 MHz Freescale MPC8541E with 256 MB of 266 MHz DDR SDRAM and 64 MB flash on PRO-4600 10 MHz, 0.75 - 2.5 Vpp drives sampling clock on XMC-3321 10 MHz drives sampling clock on XMC-3321 Supports range of 36 MHz to 300 MHz, 0.75 - 1.8 Vpp Gigabit Ethernet and RS232 via PRO-4600 J2, JTAG via PRO-4600 and XMC-3321 on-board header
[buses]	Host	3U CompactPCI card 32-bit/66 MHz
[analog I/O]	High-Speed ADC ADC Input High-Speed DAC DAC Output Jitter Phase imbalance Coupling Low-Speed ADC Low-Speed DAC	Two Analog Devices AD6645 14-bit @ 96.0 MSPS (alternate sampling rates 36 to 105 MSPS are optional) AC coupled, full scale 1.29 Vpp typical, into a 50 ohm load @ 70 MHz Two Analog Devices AD9755 14-bit @ 192.0 MSPS (alternate sampling rates up to 300 MSPS are optional) AC coupled, max 0.47 Vpp typical, into a 50 ohm load @ 70 MHz Less than 800 femtoseconds additive jitter through the analog clock distribution circuitry Less than 1 degree of phase imbalance (skew) between I/Q A/Ds at 10 MHz b/w, DC coupled AC - standard, DC - optional Quad 12-bit @ 100 KSPS Dual 12-bit @ 100 KSPS
[external interfaces]	Ethernet Low Speed Serial Analog IF Input Analog IF Output External clock/ reference User I/O JTAG Connection	Gigabit Ethernet (10/100/1000 BaseT) RS232 data 2 channels, SSMC connector, 50 ohms 2 channels, SSMC connector, 50 ohms 1 input, SSMC connector, 50 ohms GPIO lines between J2/JN4 Flex cable to header on PRO-4600 and XMC-3321
[performance]	High-Speed Data Transfer Rates	One Solano link: 200 MB/s between the XMC-3321 I/O module and the PRO-4600 carrier <ul style="list-style-type: none"> • Between the PRO-4600 crossbar and GPP: 120 MB/s read, 180 MB/s write half-duplex • Between the PRO-4600 crossbar and DSP: 60 MB/s interrupt, 180 MB/s polling half-duplex • DSP to memory via EMIF-A: 520 MB/s at 133 MHz • From the PRO-4600 GPP to memory: 1064 MB/s
[software]		Please refer to the software section of this datasheet
[electrical]	Supply Voltage (DC) Power Estimate	+3V \pm 3 % and +5 V \pm 3% 25 watts includes PRO-4600 with XMC-3321 I/O module receiving and transmitting (DACs and ADCs) and the Solano link. Power estimates do not include power required by user application code for the GPP or user programmable FPGA. Further power reduction using Spectrum MCOTS optimization available.
[mechanical]	Size	100 mm (height) x 160 mm (length)
[environmental]	Temperature RoHS	Air-cooling operating temperature range of 0 to 50 degrees C, forced air @ 600 LFM Industrial conduction-cooling card edge temperature range of -40 to +70 degrees C 5 of 6 compliant (Pb solder exemption). For RoHS ordering information, other RoHS compliance options or certificates of compliance, please contact Spectrum Sales
[ordering information]	650-00558 650-00573 650-00559 650-00574	OS configuration indicated in brackets PRO-4600-CAC with XMC-3321-CAC-SX55; SDR-4000 WML, Commercial Air-Cooled (VxWorks) PRO-4600-CAC with XMC-3321-CAC-SX55; SDR-4000 WML, Commercial Air-Cooled (INTEGRITY) PRO-4600-ICC with XMC-3321-ICC-SX55; SDR-4000 WML, Industrial Conduction-Cooled (VxWorks) PRO-4600-ICC with XMC-3321-ICC-SX55; SDR-4000 WML, Industrial Conduction-Cooled (INTEGRITY)
[custom configuration]		For custom configuration, please contact Spectrum Sales