

SDR-4001 IDS

Integrated Development System for Small Form Factor Software Defined Radio

3U
cPCI



Benefits

- Reduce time-to-deployment for SDR-4000 based architectures using a fully configured development system ready for waveform porting and application development
- Minimize program risk. Develop applications and port waveforms using a commercial-off-the-shelf (COTS) IDS. In parallel with your development, modify your SDR-4000 hardware to meet specific size, weight, power, cost and ruggedization requirements of fielded applications.
- Substantially reduce waveform development and porting costs by using preloaded data flow examples with source code relevant to your application
- Ensure code portability from lab to field with the *quicComm*[™] API, a hardware abstraction layer that is common across all Spectrum *flexComm*[™] products

Applications

The SDR-4001 IDS is used for the development or porting of waveform applications targeted for deployment on the SDR-4000 platform. Typical applications of SDR-4000 include:

- Tactical Military Communications (MILCOM)
 - ground vehicular, airborne, unmanned aerial vehicles (UAV), shipborne
- Military Satellite Communications (MILSATCOM) gateways, terminals and hubs
- Electronic Warfare (EW) including Electronic Attack - jamming

Description

Configured in a compact desktop air-cooled chassis, the SDR-4001 IDS supports up to two 3U CompactPCI SDR-4000 series wireless modems. Each wireless modem provides two IF input channels, two IF output channels and a cPCI Software Defined Radio (SDR) processing engine that employs a combination of Xilinx[®] Virtex-4[™] FPGA, TMS320C6416T DSP and MPC8541E General Purpose Processor (GPP). A rear-mounted transition module provides Gigabit Ethernet, high-speed serial, RS232 and JTAG connectivity to the SDR processing engine. Equipped with reusable system examples, the SDR-4001 IDS is ready to immediately commence waveform development and porting for systems to be deployed using SDR-4000 technology.

Features

- Includes one black-side wireless modem consisting of an XMC-3321 dual transceiver module mounted on a PRO-4600 SDR processing engine
- Includes one rear panel transition module (TM2-4900) providing Gigabit Ethernet, high-speed serial, RS232 and JTAG interfaces
- A five-slot air-cooled desktop 3U CompactPCI[®] chassis with power supply that allows configurations of up to two black-side wireless modems and optional SBC
- Reusable source code examples preloaded onto the IDS that illustrate relevant data flows between processors and cards from IF to Ethernet
- IF sampling rates up to 105 MSPS supporting industry standard 10.7, 21.4 and 70 MHz IF frequencies at bandwidths up to 36 MHz
- Separate data path and control bus ideal for wireless modem applications requiring low latency deterministic operation
- Solano[®] communications technology operates over XMC interface for high-speed, low latency deterministic data path to processing engines. Parallel RapidIO (VITA 42.1) option available as an alternative to Solano
- Software Communications Architecture (SCA) option with Core Framework, Tools and ORB
- Gigabit Ethernet hub and cables
- Green Hills[®] INTEGRITY[®] Real-Time Operating System (RTOS) with MULTI[®] or Wind River[®] VxWorks[®] RTOS with Tornado[®]

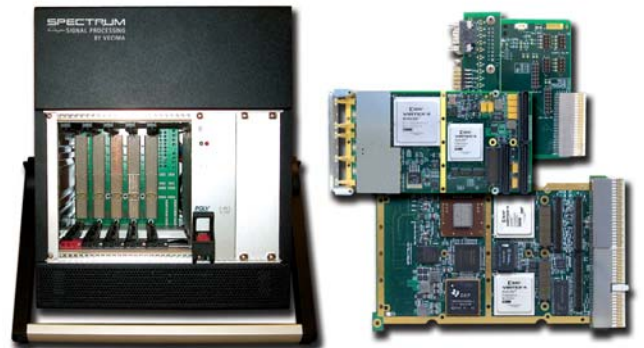

SDR-4001 IDS Integrated Development System

SDR-4001 IDS Integrated Development System Overview

The SDR-4001 IDS has been configured to allow immediate application development while Spectrum's Modified COTS (MCOTS) optimization process customizes the solution for your precise environmental needs. The IDS includes:

- One complete wireless modem board set in an air-cooled configuration:
 - PRO-4600 SDR heterogeneous processing engine employing a combination of Xilinx Virtex-4 FPGA, TMS320C6416T DSP and MPC8541E GPP
 - XMC-3321 dual channel transceiver module that supports industry standard 10.7, 21.4 and 70 MHz IF frequencies through the use of dual 14-bit A/D converters sampling at up to 105 MSPS and dual 14-bit D/A converters sampling at up to 300 MSPS in a single-width XMC form factor
- Option to scale up with additional wireless modems (XMC-3321 mounted on a PRO-4600)
- A rear panel transition module (TM2-4900) provides connectivity to the PRO-4600 Gigabit Ethernet, high-speed serial, RS232 and JTAG interface points
- A five-slot air-cooled desk-top cPCI chassis. Front access for mounting wireless modem board sets (PRO-4600 and XMC-3321) and rear access for mounting transition modules (TM2-4900). A single power supply provides +5 and +3.3 volts to the backplane. Space is available for mounting a second power supply if required. Dual fans provide cooling sufficient for most laboratory environments.
- RS232 and JTAG cables per PRO-4600 and XMC-3321
- SSMC coaxial cable kit for XMC-3321
- Gigabit Ethernet hub and CAT5e cables
- SDR-4000 series base software and documentation. Includes system example – demonstrating receiver to transmitter loopback with both receive and transmit capabilities (contact Spectrum Sales for details)
- Green Hills INTEGRITY Operating System and MULTI IDE Integrated Development Environment (optional)
- Green Hills Slingshot JTAG device and MPSServe software (optional)
- Wind River VxWorks Operating System and Tornado IDE (optional)
- Windows® XP development PC with target RTOS and software tools installed and tested (optional)
- Xilinx ISE Foundation FPGA Tools (optional)
- Texas Instruments Code Composer Studio (optional)
- Two day SDR-4000 training at Spectrum's headquarters or customer site
- Software Communications Architecture (SCA) Core Framework, tools and ORB (optional)

Modified COTS (MCOTS) Process

The PRO-4600 3U SDR processing engine and XMC-3321 dual transceiver module hardware and software architecture is based on Spectrum's Tactical MILCOM modular reference architectures allowing a quick turn-around in optimizing the products to meet the size, weight, power, cost and/or ruggedization characteristics of fielded applications. In addition to this, the PRO-4600/XMC-3321 wireless modem supports independent hard and soft real-time communications fabrics that allow rapid re-spin through the use of custom data-routing techniques. Using the MCOTS process, Spectrum works with its customers to provide an optimized solution while substantially minimizing the time-to-deployment. For more information on the benefits of Spectrum's MCOTS process, please contact Spectrum Sales.

Hardware and Software

For a complete overview of the options and development tools, please see the SDR-4000 datasheet.

[Black-Side Wireless Modem – XMC-3321 Mounted on PRO-4600]

The SDR-4001 IDS wireless modem consists of an XMC-3321 dual transceiver module mounted onto a 3U PRO-4600 processing engine card. Each wireless modem provides modem, link and network layer processing of a software defined radio. Based on Spectrum's MILCOM reference designs, the PRO-4600 and XMC-3321 have been architected to support black-side digitization and processing of complex waveforms requiring low latency deterministic operation to maintain synchronization of the frequency-hopped Tactical MILCOM network. Please see individual PRO-4600 and XMC-3321 datasheets for more detail.

[TM2-4900 Transition Module]

The TM2-4900 transition module provides a rear-chassis user interface to the wireless modem board set. One TM2-4900 module is required for each wireless modem board set (PRO-4600 and XMC-3321 combination) and provides connectivity to the PRO-4600 Gigabit Ethernet, high-speed serial, RS232 and JTAG interface points. For a chassis that supports multiple wireless modem board sets and requires high-speed serial data transferred between board sets, each TM2-4900 supports two high-speed serial link (SLINK) connectors. The TM2-4900 is used for development purposes only and is not typically required for fielded systems.

[Solano Communications Technology]

The PRO-4600 and XMC-3321, together or as standalone boards, supports two Solano ePMC links via the XMC interface. The Solano Communications Technology used in the ePMC specification provides high bandwidth deterministic data paths between ePMC mezzanine modules and ePMC carriers. Each Solano high-speed link is capable of greater than 200 MB/s full-duplex communications and features lower power consumption compared to other high-speed communications technology, such as Parallel RapidIO.

[Gigabit Ethernet Hub]

A desktop Gigabit Ethernet hub and two CAT5e cables are included with each SDR-4001 IDS. The PRO-4600 Gigabit Ethernet interface is typically used during development to download code, for debugging, wireless modem configuration and transferring payload data to the development PC for analysis purposes. Alternatively, Ethernet may be used to transfer low bandwidth non-deterministic payload or control data between wireless modems.

[Software Examples]

To provide a starting point for your application development, Spectrum’s reference software examples illustrate relevant data flows between processors and cards, exercising major components on each board. In addition, the software examples also demonstrate system functionality such as a loop-back example that provides both transmit and receive data flow across the XMC-3321 and PRO-4600 wireless modem. A system example to demonstrate a loop-back data path for receiving and transmission is shown in Figure 1.

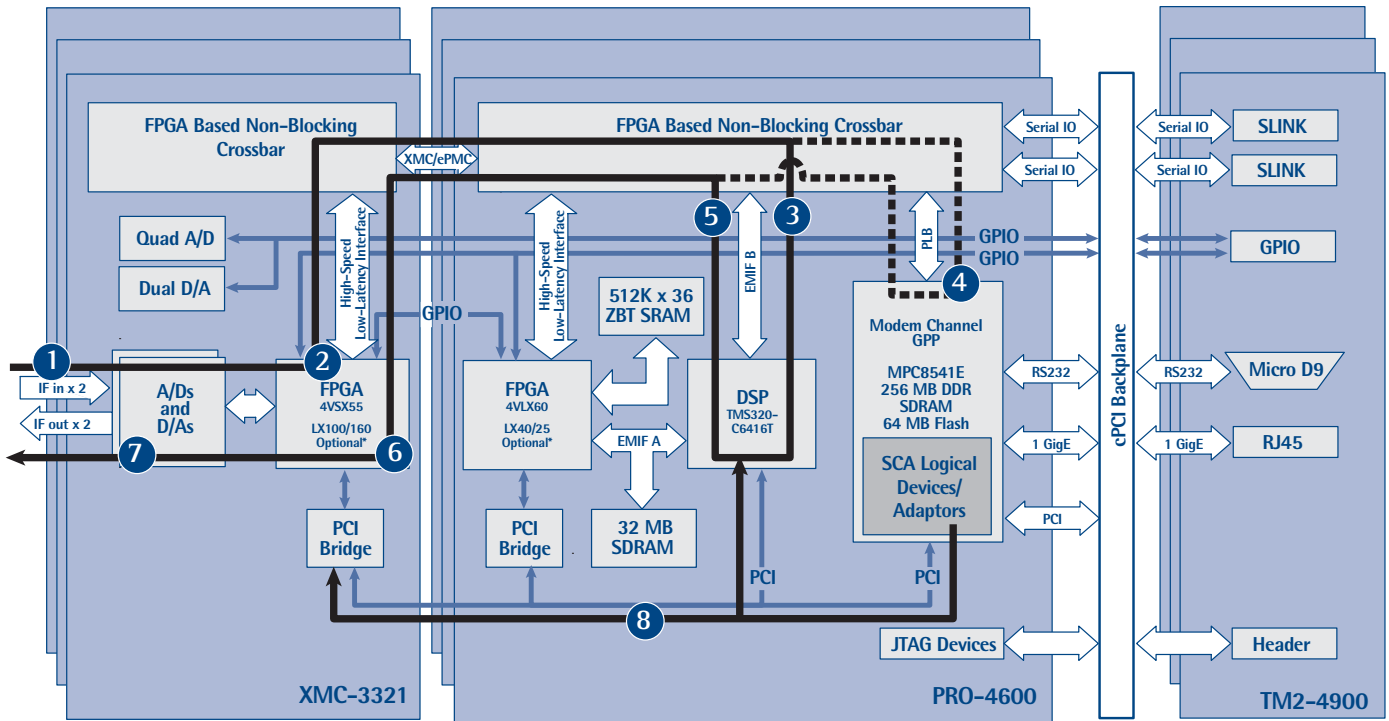

Figure 1. SDR-4001 System Example. *Please see individual datasheets for details on future options.

1. An analog 70 MHz IF signal is input via the Rx1 SSMC connector to the XMC-3321 where it is digitized in the analog to digital (A/D) converter. Signal processing is in the digital domain beyond the A/D converter.
2. The digitized IF signal is transferred to the User FPGA on the XMC-3321 for decimation.
3. The decimated signal is transferred using the Solano communications technology via the crossbar and across the EMIF-B interface to the DSP on the PRO-4600 for further decimation.
4. The DSP will then send the signal to the PRO-4600 GPP (MPC8541E) where it is routed back to the PRO-4600 DSP.
5. The signal is then sent from the DSP on the PRO-4600 back to the XMC-3321 User FPGA via the EMIF-B link and crossbar.
6. In the XMC-3321 User FPGA the signal is up-sampled.
7. The digital sample stream is converted to analog in the XMC-3321 digital to analog (D/A) converter and output through the SSMC Tx1 connector.
8. The MPC8541E GPP controls the DSP on the PRO-4600 and the User FPGA on the XMC-3321 via the PCI bus.

[Operating System]

The SDR-4001 IDS can be shipped with the VxWorks OS or the INTEGRITY OS for the MPC8541E processor of the PRO-4600. For more details, please see SDR-4000 datasheet.

[quicComm Application Programming Interface]

The PRO-4600 and XMC-3321 software application programming interface (API) is provided via Spectrum’s *quicComm* SDK. *quicComm* software abstracts the underlying hardware providing users with basic link level access and control of Spectrum’s *flexComm* products which significantly accelerates user application development. It is standard across all *flexComm* products, allowing code portability. For more information on *quicComm*, please consult the *quicComm* datasheet.

[Software Communications Architecture (SCA)]

The SCA option provides a complete SCA-compliant software operating environment including implementations of the SCA Core Framework, associated tools and Object Request Broker (ORB). Please contact Spectrum Sales for more information.

Specifications

[general]	Baseband Processing IF Conversion User Interface Chassis	PRO-4600 SDR processing engine (see standalone datasheet for details) XMC-3321 dual transceiver module (see standalone datasheet for details) TM2-4900 transition module with JTAG, RS232, Gigabit Ethernet and SLINK connectivity Five slot front and rear backplane, air-cooled, 3U cPCI
[buses]	Host	3U cPCI bus (32-bit/33 MHz)
[external interfaces]	Ethernet Low-speed serial Analog Input Analog Output External clock/reference FPGA Download/debug High-speed serial	Gigabit Ethernet (10/100/1000 BaseT) on the TM2-4900 rear panel RS232 data 2 channels, SSMC connector, 50 ohms (see XMC-3321 datasheet) 2 channels, SSMC connector, 50 ohms (see XMC-3321 datasheet) 1 input, SSMC connector, 50 ohms (see XMC-3321 datasheet) JTAG header connection on TM2-4900 Two links per modem (optional) @ 320 MB/s typical
[performance]	Data Transfer Rates	See the following Spectrum datasheets for details: PRO-4600 SDR Processing Engine XMC-3321 Dual Transceiver Module SDR-4000 Series, Software Defined Radio, Small Form Factor Transceiver Platform
[software]		Spectrum's <i>quicComm</i> INTEGRITY and MULTI or VxWorks and Tornado (optional). Please see the PRO-4600 datasheet for details. Code Composer Studio (optional) ISE Foundation Tool Flow (optional) SCA-compliant software operating environment (optional)
[environmental]	Ambient temperature Storage temperature Humidity RoHS	Operational temperature range of 0 to 25 °C 0 to +60° C 10% to 90% relative humidity, non-condensing, no conformal coating Please see component level datasheets for RoHS compliance or contact Spectrum Sales
[ordering information]		Contact your Spectrum Sales Representative for specific ordering information. Expect to cover the following items (OS configuration indicated in brackets): 901-00032 SDR-4001 Integrated Development System (VxWorks) 901-00038 SDR-4001 Integrated Development System (INTEGRITY) All SDR-4001 Integrated Development Systems includes the following: <ul style="list-style-type: none"> • Wireless modem board set: XMC-3321 (with SX55 User FPGA) mounted on PRO-4600 (with LX60 User FGPA) • Transition module: TM2-4900 • Chassis with power supply and backplane: 3U cPCI, air-cooled • Gigabit Ethernet hub and RJ45 CAT5e cable • Cable kits include RS232 serial, JTAG and SSMC cables Supporting Products The following SDR-4001 equipment, software and services may also be required. Contact Spectrum Sales for details. 100-00514 SDR-4000 series base software and documentation (VxWorks) 100-00524 SDR-4000 series base software and documentation (INTEGRITY) 800-00260 Development laptop computer 650-00555 Wireless modem board set: XMC-3321 dual transceiver module with SX55 User FPGA mounted on PRO-4600 SDR processing engine with LX60 User FPGA, air-cooled (VxWorks) 650-00563 Wireless modem board set: XMC-3321 dual transceiver module with SX55 User FPGA mounted on PRO-4600 SDR processing engine with LX60 User FPGA, air-cooled (INTEGRITY) 650-00549 XMC-3321 dual transceiver module, SX55 User FPGA, air-cooled 600-00587 PRO-4600 SDR processing engine, LX60 User FPGA, air-cooled (VxWorks) 600-00583 PRO-4600 SDR processing engine, LX60 User FPGA, air-cooled (INTEGRITY) 600-00449 TM2-4900 transition module Contact Spectrum Sales Operating system, SCA support and tools 100-00489 ISE Foundation Tool Flow 700-00100 DSP development kit including Code Composer Studio FPGA Cores FPGA IP cores are licensed to the device type. Contact Spectrum Sales SDR-4000 and SCA training courses and Support packages are offered at Spectrum's headquarters or at your site.
[custom configuration]		For custom configuration, please contact Spectrum Sales
[export regulations]		The SDR-4001 IDS is subject to the export control laws of Canada The SDR-4001 IDS is NOT subject to the United States International Traffic in Arms Regulations (ITAR)