

XMC-2131 DAC

Dual 14-bit High-Speed Digital-to-Analog Converter and Xilinx Virtex-5 Processing Engine

XMC

Preliminary



Benefits

- Enables coherent sampling over multiple boards, with GPS-based time synchronization
- Flexible platform that enables modular architecture design
- High-speed, low latency, deterministic data paths from carrier board

Applications

- Signals Intelligence (Wideband Spectral Analysis, Multichannel Direction Finding)
- Electronic Support Measures
- Electronic Countermeasures
- Phased Array Surveillance RADAR
- Military Communications/Military Satellite Communications including wireless gateways and satellite earth stations

Features

- Two 14-bit D-to-A converters sampling up to 300 MSPS
- XMC and Parallel RapidIO™ compatible module
- Can function as an enhanced PMC (ePMC) module using Solano Technology high-speed, low latency, deterministic data paths to processing engines
- A single user programmable Xilinx® Virtex-5™ FPGA device for wideband processing
- Total available bandwidth greater than 400 MB/s full duplex communication
- Two banks of 256 MB of DDR2 additional SDRAM memory available to the user FPGA
- 32-bit/33 MHz PCI host bus interface for control and data transfer. 66 MHz available as a future option*.
- JTAG connector compatible with Xilinx's ChipScope™ debugger
- 34-pin front panel digital I/O

Description

The XMC-2131 is a key component in Spectrum's series of software defined digital radio modules from the *flexComm*™ wireless communications product line. The XMC-2131 has dual output 14-bit D/A converters, each running at up to 300 MSPS in a single-width VITA 42.0 XMC form factor. The DACs are integrated with a single user programmable Xilinx Virtex-5 FX130T FPGA device for wide bandwidth signal processing and filtering in the digital domain. The module can also be used as an Enhanced PMC (ePMC) module. The ePMC standard is fully compatible with IEEE P1386.1 PMC standard but offers the additional benefit of dedicated rapid Solano links between ePMC compliant carrier and mezzanine modules. Data can also be transferred over PCI, which provides the control path.



* See future options section of this datasheet.

This product is preliminary. Minimum order quantities may apply. Lead times are subject to change. Spectrum reserves the right to change the specifications without warning until final product is available. Please contact Sales for more information.

Block Diagram

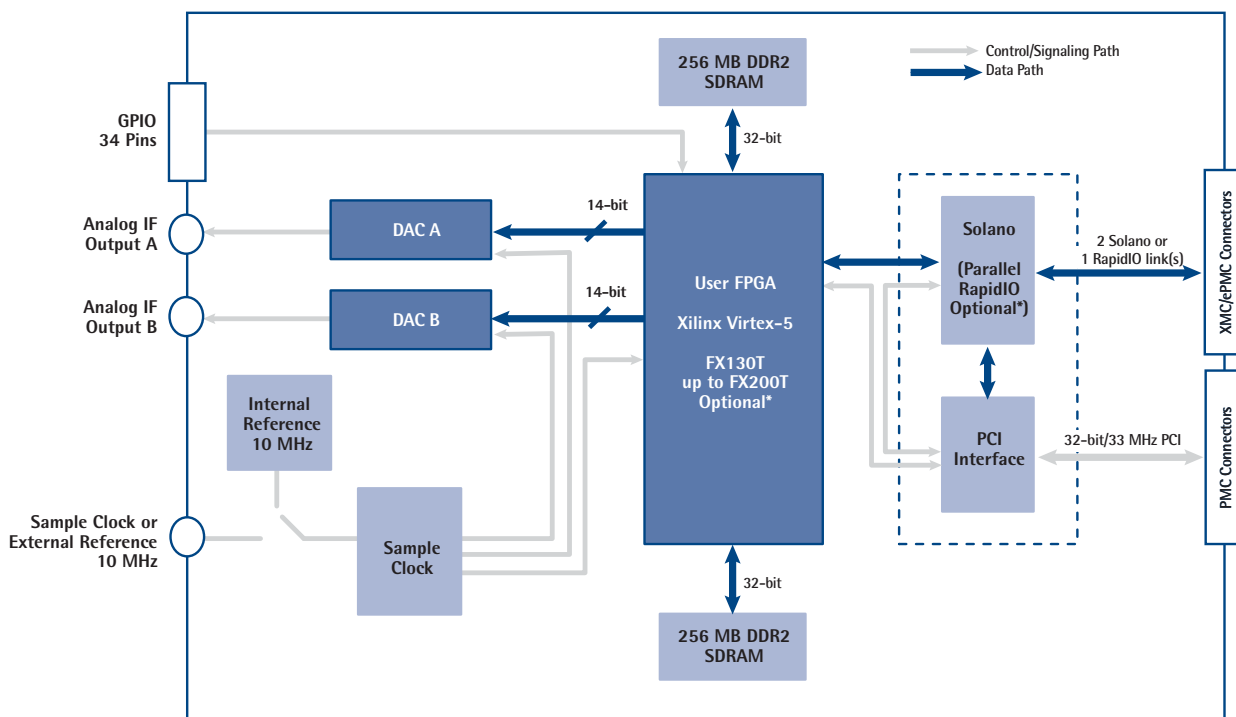

Figure 1. XMC-2131 Block Diagram

Architecture

[XMC and Parallel RapidIO*]

The XMC-2131 is a VITA 42.0 XMC compliant module. The VITA 42.0 XMC Mezzanine Card standard defines physical features that enable switched communications between a standard mezzanine card and its carrier. These features include the addition of two connectors carrying the additional electrical signals necessary for such communications.

As a future option*, the XMC-2131 may be made compliant with the VITA 42.1 Parallel RapidIO standard that uses a point-to-point scalable switched-fabric for its transport layer. The standard uses LVDS signaling with a double-data-rate clocking methodology, and supports both 8 and 16-bit link widths. The XMC-2131 module may support two 8-bit link widths (one per XMC connector) at 500 MB/s per link.

[ePMC - Solano Communications Technology]

The XMC-2131 is an ePMC module, employing Solano Communications technology that provides high bandwidth data paths between ePMC mezzanine modules and ePMC carriers. Each Solano high-speed link is capable of greater than 200 MB/s full-duplex communications. A data network implemented using this Solano Communications technology provides system throughput that can be many times higher than that offered by conventional based or serial link architectures. The XMC-2131 Solano Communication fabric enables the module to simultaneously transmit and receive data streams to/from other processing units at a sustained 400 MB/s per channel.

[Xilinx Virtex-5]

The Virtex-5 platform FPGA combines a large amount of programmable logic, embedded Intellectual Property (IP) cores, advanced clocking circuitry, and embedded memory with versatile, fast interconnect structures. The Virtex-5 FX130T device features 20,480 V5 slices (4 LUTs and 4 FFs each) combined with 10,728 kbits of embedded block RAM. It also includes 320 DSP48E slices, each with a 25 x 18 multiplier, an adder and an accumulator.

[D/A Converters]

The XMC-2131 uses two AD9755 14-bit DACs sampling at rates from 110 to 300 MSPS. Single-tone SFDR is a minimum of 65 dB at 10.7 and 70 MHz. The output is transformer coupled with a passband of 0.5 MHz to 90 MHz. DC-coupled analog outputs are available as a future option.*

[Sample Clock]

An onboard VCXO is included for a sample rate of 300 MSPS. Other VCXO/VCXO frequencies are available as a future option*. The onboard VCXO may be referenced to an external reference input (nominally 10 MHz). The sample clock may be supplied from an external source for sampling rates of 110 to 300 MSPS.

[Front Panel GPIO]

A General Purpose I/O (GPIO) connector is available on the front panel. This connector allows access to 15 differential input/output LVDS pairs, 2 LVTTTL data and 2 LVTTTL global clock bi-directional pins for synchronization, triggering, timestamping, and RF receivers/transmitters control. Multiple XMC-2131 modules can be synchronized to each other via the GPIO connector. This connector also allow the synchronization with frequency references, IRIG-B time stamp and software initiated events.

Software

[*quicComm*[™] Software Development Kit (SDK)]

quicComm software equips users with basic link level access and control of Spectrum's *flexComm* products. *quicComm* significantly accelerates user application development. It is also standard across all *flexComm* products, allowing code portability. This software includes a board support package for control and data handling which:

- Allows configuration and control of the Solano links between the processors and the ePMC modules
- Initiates and manages data transfers
- Manages interrupts
- Enables dynamic loading on a processor without affecting other processors

As a part of Spectrum's *quicComm* package, an FPGA wrapper is provided to abstract all board level interfaces on the Virtex-5 user FPGA, including the interfaces to the analog converters, communication fabrics and control. The wrapper is designed so users can expedite the integration of third party or custom FPGA IP cores into the XMC-2131 module.

[Xilinx's ISE Foundation]

ISE Foundation is an integrated programmable logic design environment. It includes: schematic capture, power analysis tools, physical synthesis for FPGAs, advanced Place and Route Algorithms, HDL Advisors, and Timing Cross-Probing. ISE Foundation also contains COREgenerator, a graphical interactive design entry tool that is used to create high-level modules. COREgenerator gives access to a library of hundreds of FPGA IP cores, many of them free, from Xilinx and third-party vendors. This library includes DSP applications such as digital down converters (DDC), direct digital synthesizers (DDS), FIR filters, FFT, numerically controlled oscillator (NCO), memory controller, and much more.

[RF Engines]

Spectrum has partnered with RF Engines Ltd. (www.rfel.com) to offer integrated IP cores and turnkey designs for digital RF signal processing in FPGAs to speed development. RF Engines' IP cores are highly optimized in terms of speed, power and size compared to cores available from the major FPGA vendors. As an option, Spectrum can integrate the following RF Engines FPGA IP cores: dual 16K point FFT, 32K point FFT, tunable multi-channel receiver, distributed half band filter, and fixed point to floating point converter core.

For application specific requirements, Spectrum can develop custom cores for clients when these are otherwise unavailable. If you have such a requirement, please contact Spectrum Sales.

* See future options section of this datasheet.

Specifications

[general]	FPGA Device External Reference Oscillator	A single user-programmable Xilinx Virtex-5 FX130T Nominally 10 MHz sample clock reference, 0.75 - 1.6 Vpp
[analog output]	D/A Converter DAC Output DAC SFDR	Two Analog Devices AD9755 14-bit @ 300 MSPS @ up to 300 MHz Standard product is equipped with a 600 MHz VCSO for sampling at 300 MSPS on the internal clock AC coupled, max of 0.61 Vpp into a 50 ohm load when driven at +/- full scale 3dB output bandwidth: 500 kHz - 90 MHz @300 MSPS, single tone -1 dBFS 10.7 MHz IF (10 MHz BW) > 80 dB typical 21.4 MHz IF (20 MHz BW) > 75 dB typical 70 MHz IF (30 MHz BW) > 75 dB typical
[external interfaces]	Analog IF Input/Output, External Sampling Clock or 10 MHz Reference PMC host PCI bus JTAG Connection ePMC Interface	SMA Socket 50 ohms SMA Socket 50 ohms, 110 to 300 MHz, 0.75 - 1.6 Vpp 32-bit/33 MHz PCI interface following IEEE P1386.1 specification JTAG connector for Virtex-4/5 FPGA, Xilinx ChipScope™ debugger compatible Two Spectrum Solano links, each providing greater than 200 MB/s (full-duplex)
[compatibility]	Carrier Operating System	PRO-1900/PRO-1901 Contact Spectrum Sales for other carriers Refer to carrier specifications
[development software]	Application Libraries FPGA Code Development HDL coding language	<i>quicComm</i> Software Development Kit ISE Foundation tools from Xilinx and ModelSim® PE from Model Technology are required, Synplify Synthesis® from Synplcity is recommended VHDL
[electrical]	Supply Voltage (DC) Current Consumption	Supply Voltage +5V, 3.3V +5%/-3% (supplied by PMC connector) TBD
[environmental]	Temperature RoHS	Air-cooling operating temperature range of 0 to 50 degrees C, forced air @ 600 LFM 5 of 6 compliant (Pb solder exemption). For RoHS ordering information, other RoHS compliance options or certificates of compliance, please contact Spectrum Sales.
[ordering information]		This product is preliminary. Minimum order quantities may apply. Lead times are subject to change. Spectrum reserves the right to change the specifications without warning until final product is available. Please contact Sales for more information. 650-00595 XMC-2131_CAC_FX130T-1_256M Dual DAC 300 MSPS 14b V5FX130T-1, 256MB DDR2
[compatible modules]	ePMC-8120 ePMC-PPC	Xilinx Virtex-II Processing Engine PowerPC Processing Module
[future options]	Alternate PMC Host PCI Bus XMC Interface Sample Clock Alternate I/O Alternate Carrier Additional Modules	Future options may be implemented at the discretion of Vecima Networks Inc. or its subsidiaries based on market demand.** 66 MHz PCI interface Two 8-bit Parallel RapidIO links Alternate VCXO frequencies DC coupled analog outputs PRO-2900, PRO-3500, PRO-4600 XMC-8131 FPGA Processing Engine XMC Module